

AES PROFESSIONAL

Energy Storage System

INSTALLATION AND OPERATION MANUAL

BATTERY MODELS

DLP-GC2-12V		900-0051
DLP-GC2-24V		900-0052
DLP-GC2-36V		900-0053
DLP-GC2-48V		900-0054



1. AUDIENCE, MESSAGES, WARNINGS, GENERAL SAFETY, PERSONAL PROTECTIVE EQUIPMENT . . .	3
1.1 Audience	3
1.2 Messages	3
1.3 Warning and General Safety	4
1.4 Safe Handling Procedures	4
1.5 Personal Protective Equipment	5
2. SPECIFICATIONS	5
2.1 Electrical Specifications	5
2.2 Mechanical Specifications	6
2.3 Environmental Specifications	6
2.4 Protection Specifications	7
2.5 Internal Heating Specifications	8
2.6 Minimum Size Specifications for Battery Systems	8
2.7 Regulatory	10
3. TRANSPORTATION	11
4. HANDLING	11
5. FEATURES	11
5.1 Battery Fuse	11
5.2 PTFE Membrane Vent	11
5.3 Battery ON/OFF Key	12
5.4 At-a-glance LED	12
5.5 LYNK Port	12
5.6 Lifting Points	13
6. THEORY OF OPERATION	13
6.1 Ingress Protection IP67	13
6.2 Internal Heating	13
6.3 Battery Management System	14
6.4 LYNK Network Communication	15
7. OPTIONAL ACCESSORIES	17
8. INSTALLATION	17
8.1 Tools	17
8.2 Location	18
8.3 DC Cables	18
8.4 DC Protection	19
8.5 Terminal Connections and Hardware	19
8.6 Single Battery Installation Procedure	20
8.7 Parallel Battery Installation Procedure	21
8.8 LYNK Network	23
9. OPERATION	25
9.1 Low Voltage Cut-Off	25
9.2 State of Charge	25
9.3 Charging	25
9.4 Charging Profile	28
10. ROUTINE INSPECTION	30
11. REPLACING THE FUSE	30
12. STORAGE	31
13. BATTERY FIRMWARE AND DATA LOGS	32
14. TROUBLESHOOTING	32
15. RELATED INFORMATION	32
16. GLOSSARY OF TERMS, ABBREVIATIONS, AND ACRONYMS	32

READ AND SAVE THESE INSTRUCTIONS

1. AUDIENCE, MESSAGES, WARNINGS, GENERAL SAFETY, PERSONAL PROTECTIVE EQUIPMENT

1.1 Audience

Certain configuration, installations, service, and operating tasks should only be performed by qualified personnel in consultation with local authorities having jurisdiction and authorized dealers. Qualified personnel should have training, knowledge, and experience in:

- Installing electrical equipment
- Applying applicable installation codes
- Analyzing and reducing hazards involved in performing electrical work
- Installing and configuring batteries

1.2 Messages

Messages on the battery and in this manual are formatted according to this structure.



WARNING -To reduce the risk of injury, user must read instruction manual. Read all the instructions before installation, operation, and maintenance.



Do not crush, disassemble or dispose of the battery in fire or the garbage.



This product must be recycled and is made of recyclable materials.



Important information regarding hazardous conditions.

⚠ WARNING

Important information regarding hazardous conditions that may result in personal injury or death.

⚠ CAUTION

Important information regarding hazardous conditions that may result in personal injury.

NOTICE

Important information regarding conditions that may result in damage to the equipment but not personal injury.

NOTE

Ad hoc information concerning important procedures and features of the battery not related to personal injury or equipment damage.

1.3 Warning and General Safety



⚠ WARNING

ELECTRIC SHOCK AND FIRE HAZARD

- This equipment must only be installed as specified.
- Do not disassemble or modify the battery.
- If the battery case has been damaged, do not touch exposed contents.
- No user-serviceable parts inside.

Failure to follow these instructions may result in death or serious injury.

⚠ WARNING

CHEMICAL HAZARD

Do not touch the exposed contents of a Lithium cell.

Failure to follow these instructions may result in death or serious injury.

⚠ WARNING

ELECTRIC SHOCK AND FIRE HAZARD

Do not lay tools or other metal parts on top of the battery or across the terminals.

Failure to follow these instructions may result in death or serious injury.

⚠ CAUTION

ELECTRIC SHOCK

- Do not touch the energized surfaces of any electrical component in the battery system.
- Before servicing the battery, follow all procedures to fully de-energize the battery system.
- Follow the "Safe Handling Procedures" below when handling the battery.

Failure to follow these instructions may result in injury.

1.4 Safe Handling Procedures

Before using the battery, read all instructions and cautionary markings on the unit and all appropriate sections of this manual.

- Use personal protective equipment when working with batteries.
- Do not dispose of the battery in fire.
- Promptly dispose or recycle used batteries following local regulations.
- Do not disassemble, open, crush, bend, deform, puncture or shred.
- Do not modify, re-manufacture, attempt to insert foreign objects into the battery, immerse or expose to water or other liquids, expose to fire, explosion, or other hazards.
- Only use the battery for the system for which it is specified.
- Do not lift or carry the battery while in operation.

- When lifting a heavy battery, follow the appropriate standards.
- Only lift, move, or mount following local regulations.
- Take care when handling battery terminals and cabling.
- Only use the battery with a charging system that has been qualified for the system. The use of an unqualified battery or charger may present a risk of fire, explosion, leakage, or other hazards.
- Do not short circuit a battery or allow metallic conductive objects to contact battery terminals.
- Replace the battery only with another battery that has been qualified for the system. The use of an unqualified battery may present a risk of fire, explosion, leakage, or other hazards.
- Avoid dropping the device or battery. If the device or battery is dropped, especially on a hard surface, and the user suspects damage, take it to a service center for inspection.

1.5 Personal Protective Equipment

- Use Personal Protective Equipment, including clothing, glasses, insulated gloves, and boots.
- Do not wear rings, watches, bracelets, or necklaces when handling or working near the battery.

2. SPECIFICATIONS

Specifications are published at 25°C / 77°F

2.1 Electrical Specifications

Table 2-1. DLP-GC2 Electrical Specifications

Electrical Spec	DLP-GC2-12V 900-0051	DLP-GC2-24V 900-0052	DLP-GC2-36V 900-0053	DLP-GC2-48V 900-0054
Nominal Voltage	12.8 V	25.6 V	38.4 V	51.2 V
Energy	1536 Wh	1536 Wh	1152 Wh	1536 Wh
Capacity 1Hr	120 Ah	60 Ah	30 Ah	30 Ah
Fast Charge - Bulk Vdc - U1	14.2 V	28.4 V	42.6 V	56.8 V
Fast Charge - Absorption Vdc - U2	13.8 V	27.6 V	41.4 V	55.2 V
Rated Charge - Bulk Vdc - U2	13.8 V	27.6 V	41.4 V	55.2 V
Rated Charge - Absorption Vdc - U2	13.8 V	27.6 V	41.4 V	55.2 V
Float Vdc - U3	13.6 V	27.2 V	40.8 V	53.6 V
Charge Termination Current ^a	3.00 A	1.50 A	0.75 A	0.75 A
Low Voltage Disconnect Recommended	12.0 V	24.0 V	36.0 V	48.0 V
Low Voltage Disconnect	10.0 V	20.0 V	30.0 V	40.0 V
Max Discharge Current (1 hour)	120 A	115 A	58 A	58 A
Max Continuous Discharge Current	60 A	30 A	15 A	15 A
Max Charge Current (1 hour)	115 A	58 A	29 A	29 A
Max Continuous Charge Current	60 A	30 A	15 A	15 A

Peak Discharge Current (3 seconds)	360 A RMS	180 A RMS	90 A RMS	90 A RMS
Fuse	58 V 200 A	58 V 125 A	58 V 60 A	58 V 60 A
Maximum Load Input Capacitance	49 mF	106 mF	51 mF	23 mF
^a Charge current termination is permitted to be less than specified. Note: When the charger termination current is lowered, the internal balancing function has more time to operate.				

2.2 Mechanical Specifications

Table 2-2. DLP-GC2 Mechanical Specifications

Mechanical Spec.	DLP-GC2-12V 900-0051	DLP-GC2-24V 900-0052	DLP-GC2-36V 900-0053	DLP-GC2-48V 900-0054
Chemistry	LiFePO ₄			
Length	260 mm (10.2 in)			
Width	180 mm (7.1 in)			
Total Height	275 mm (10.8 in)			
Terminal	5/16 in Stud (Height 22 mm) 5/16 in Button Insert (Depth 18 mm)			
Terminal Torque	8 to 10 Nm (5.9 to 7.4 ft-lb). DO NOT EXCEED 10 Nm (7.4 ft-lb).			
Weight	14.0 kg (30.7 lb)	14.0 kg (30.7 lb)	11.2 kg (24.7 lb)	14.0 kg (30.7 lb)
IP Rating	IP 67			
Case Material	UL94-5VA PBT/PC			

2.3 Environmental Specifications

Table 2-3. DLP-GC2 Environmental Specifications

Environmental Spec.	All Models
Rated Altitude	Altitude does not significantly affect operating characteristics up to 2,000 m (6,561 ft)
Charge Operating Temperature Range ^{a,b}	4°C to 42°C (39.2°F to 107.6°F)
Discharge Operating Temperature Range ^a	-17°C to 52°C (1.4°F to 125.6°F)
Internal Heater Operating Temperature Range ^c	-17°C to 8°C (1.4°F to 46.4°F)
Storage Temperature (1 month) ^d	-20°C to 45°C (-4°F to 113°F)
Storage Temperature (6 months) ^d	-10°C to 30°C (14°F to 86°F)
^a This is the specified temperature of the cells and not ambient. Ambient temperature and cell temperature may not be the same.	
^b Although the Battery Management System (BMS) does not allow charging when cells are below 4°C (39.2°F), the battery has an internal heater that warms the battery to a temperature that enables charging to resume at 4°C (39.2°F).	
^c When the battery cells are between -17°C (1.4°F) and 5°C (41°F) and either connected to a charging source or SOC is 50% or more, energy is diverted to the internal heater until the battery reaches 8°C (46.4°F).	
^d Storage outside of specified temperatures will result in permanent capacity loss and void the warranty.	

2.4 Protection Specifications

Table 2-4. DLP-GC2 Protection Specifications

Protection Spec.	DLP-GC2-12V 900-0051	DLP-GC2-24V 900-0052	DLP-GC2-36V 900-0053	DLP-GC2-48V 900-0054
Overvoltage				
Protection ^a	> 14.56V for 3.2 s	> 29.12 V for 3.2 s	> 43.68 V for 3.2 s	> 58.24 V for 3.2 s
Recovery ^a	Recovery after 120s and < 13.4V	Recovery after 120s and < 26.8V	Recovery after 120s and < 40.2V	Recovery after 120s and < 53.6V
Undervoltage				
Protection ^b	< 10 V for 5.2 s	< 20 V for 5.2 s	< 30 V for 5.2 s	< 40 V for 5.2 s
Recovery ^b	No automatic recovery. The battery will shut down after 120 seconds			
Over-charge Current				
Protection	> 132 A for 10 s	> 66 A for 10 s	> 33 A for 10 s	> 33 A for 10 s
Recovery	Recovery after 120 seconds			
Over-discharge Current				
Protection ^c	3-second rating 350 A	3-second rating 219 A	3-second rating 105 A	
Recovery ^c	Recovery after 120 seconds			
Over-temperature in Discharge				
Protection ^d	Cell temperature above 52°C (125.6°F) for 6.2 seconds			
Recovery ^d	Cell temperature below 48°C (118.4°F)			
Under-temperature Discharge				
Protection ^d	Cell temperature below -17°C (1.4°F) for 6.2 seconds			
Recovery ^d	Cell temperature above -15°C (5°F)			
Over-temperature in Charge				
Protection ^d	Cell temperature above 42°C (107.6°F) for 5 seconds			
Recovery ^d	Cell temperature below 38°C (100.4°F)			
Under-temperature in Charge				
Protection ^d	Cell temperature below 4°C (39.2°F) for 5 seconds and charge current detected			
Recovery ^d	Charge recovery temperature > 4°C (39.2°F) Note: Discharge will continue to be available to -17°C (1.4°F). Recover after 120 s to test for presence of charge or discharge current.			
Load Qualification Protection				
Protection	Mixed System Voltage, Short Circuit, Reverse Polarity, Input Capacitance Overload			
Recovery	Re-Qualify after 120 s. After 10 failed attempts to qualify, the battery will switch OFF			
^a . Overvoltage protection monitors individual cell voltages. Protection will trigger when any cell is over 3.64 VPC and recover when all cells are below 3.35 VPC for 120 seconds. Voltages are provided for guidance only. ^b . Undervoltage protection monitors individual cell voltages. Protection will trigger with any cell under 2.5VPC and switch the battery OFF. Manually switch the battery to ON to recover. Voltages are provided for guidance only. ^c . See Figure 1 Over-Discharge Protection Time Current Curve for time vs current interrupt detail. ^d . This is the specified temperature of the cells and not ambient. Ambient temperature and cell temperature may not be the same.				

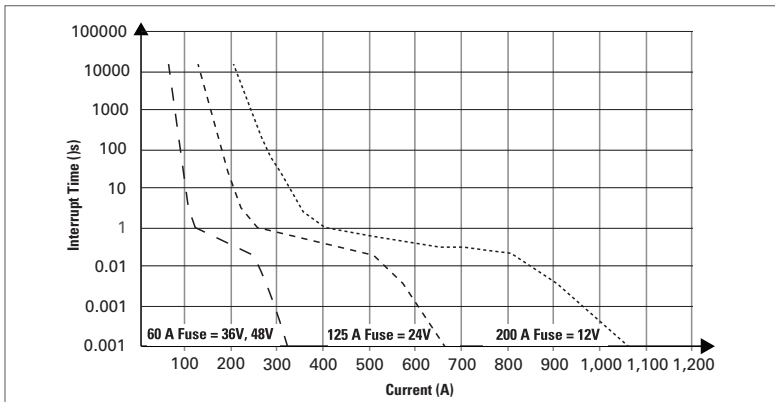

Figure 1. Over-Discharge Protection Time Current Curve

2.5 Internal Heating Specifications

Table 2-5. DLP-GC2 Internal Heating Specifications

Internal Heating Spec.	DLP-GC2-12V 900-0051	DLP-GC2-24V 900-0052	DLP-GC2-36V 900-0053	DLP-GC2-48V 900-0054
Heating Power	50 W	50 W	50 W	50 W
Heating On ^a	<ul style="list-style-type: none"> Below 5°C (41°F), and Either charge current detected or SOC is 50% or more 			
Heating Off ^a	<ul style="list-style-type: none"> Temperature above 8°C (46.4°F), or No charge current detected and SOC is less than 50% 			

^a. Specifies the temperature of the cells and not the ambient temperature. Ambient temperature and cell temperature may not be the same.

2.6 Minimum Size Specifications for Battery Systems

DLP-GC2 batteries installed in parallel in a battery bank configuration will increase system capacity. Overall battery system capacity must be correctly sized to meet the requirements of the load and account for:

- Total Max Charge Current (1 hour)
- Total Max Continuous Charge Current
- Total Peak Current
- Total Max Discharge Current (1 hour)
- Total Max Continuous Discharge Current

If charging for 1 hour or less at a time, the total charging capacity of all charging sources in the system should not exceed the Max Charge Current (1 hour) operating limit of all the batteries in the system. The same is true if discharging for 1 hour or less at a time. The total discharging capacity of all loads in the system should not exceed the Max Discharge Current (1 hour) operating limit of all the batteries in the system.

If charging and discharging for repeated cycles, the total charging capacity of all charging sources in the system should not exceed the Max Continuous Charge Current and Max Continuous Discharge Current operating limits of all the batteries in the system.

If the Max Charge Current (1 hour) or Max Discharge Current (1 hour) is exceeded for any battery in the system, the BMS in that battery will trigger the over-current protection and disconnect. The charging system’s maximum charge current must be below the operating limit of installed batteries or be curtailed.

If the Max Continuous Charge Current or Max Continuous Discharge Current is exceeded for multiple cycles, the battery is quicker to trigger the over-temperature protections and disconnect.

The sum of all the Peak Current values for the attached loads must be less than the Peak Current of the batteries system, including inrush current values, for any motors and surge values for any inverters.

NOTICE	
<ul style="list-style-type: none"> Exceeding the Peak Current, or continually exceeding the Max Charge Current (1 hour), Max Discharge Current (1 hour), Max Continuous Charge Current, or Max Continuous Discharge Current, of all the batteries in the system will lead to triggering the battery BMS over-temperature protection quicker, resulting in disconnection of all batteries in the system. Disconnection will result in a voltage spike (Load Dump), which may damage any component electrically attached to the battery system. 	

For DLP batteries installed in parallel in a battery bank configuration, the sum of all battery capacities provides the overall capacity value for the battery system. **Tables 2-6, 2-7, 2-8, and 2-9** provide DC capacity values for sample battery systems.

NOTE	
The maximum number of batteries that can be installed in a parallel configuration is 20.	

Table 2-6. DLP-GC2-12V - DC Capacity Values for Sample Battery Systems.

Parallel System	Peak Current	Max Discharge (1 hr)	Max Continuous Discharge	Max Charge (1 hr)	Max Continuous Charge	Energy/ Usable Capacity	Reserve Capacity at 25A
2 Batteries	720 A	240 A	120 A	230 A	120 A	3072 Wh	576 minutes
3 Batteries	1080 A	360 A	180 A	345 A	180 A	4608 Wh	864 minutes
4 Batteries	1440 A	480 A	240 A	460 A	240 A	6144 Wh	1152 minutes

Table 2-7. DLP-GC2-24V - DC Capacity Values for Sample Battery Systems.

Parallel System	Peak Current	Max Discharge (1 hr)	Max Continuous Discharge	Max Charge (1 hr)	Max Continuous Charge	Energy/ Usable Capacity	Reserve Capacity at 25A
2 Batteries	360 A	230 A	60 A	116 A	60 A	3072 Wh	288 minutes
3 Batteries	540 A	345 A	90 A	174 A	90 A	4608 Wh	432 minutes
4 Batteries	720 A	460 A	120 A	232 A	120 A	6144 Wh	576 minutes

Table 2-8. DLP-GC2-36V - DC Capacity Values for Sample Battery Systems.

Parallel System	Peak Current	Max Discharge (1 hr)	Max Continuous Discharge	Max Charge (1 hr)	Max Continuous Charge	Energy/ Usable Capacity	Reserve Capacity at 25A
2 Batteries	180 A	116 A	30 A	58 A	30 A	2304 Wh	144 minutes
3 Batteries	270 A	174 A	45 A	87 A	45 A	3456 Wh	216 minutes
4 Batteries	360 A	232 A	60 A	116 A	60 A	4608 Wh	288 minutes

Table 2-9. DLP-GC2-48V - DC Capacity Values for Sample Battery Systems.

Parallel System	Peak Current	Max Discharge (1 hr)	Max Continuous Discharge	Max Charge (1 hr)	Max Continuous Charge	Energy/ Usable Capacity	Reserve Capacity at 25A
2 Batteries	180 A	116 A	30 A	58 A	30 A	3072 Wh	144 minutes
3 Batteries	270 A	174 A	45 A	87 A	45 A	4608 Wh	216 minutes
4 Batteries	420 A	232 A	60 A	116 A	60 A	6144 Wh	288 minutes

2.7 Regulatory

Table 2-10. DLP-GC2 Regulatory

Regulatory
UN38.3Transportation
IEC 62619
UL 2271 (OEM installed / factory installed)
CE

3. TRANSPORTATION

If the battery is not installed in equipment, it must be transported in the original package or equivalent. According to the UN Handbook of Tests and Criteria, Batteries are tested to part III, subsection 38.3 (ST/SG/AC.10/11/ Rev. 5). For transport, the batteries belong to category UN3480, Class 9.

4. HANDLING

Before handling:

- Keep the battery away from sparks and flames
- Disconnect the cables from the battery
- Battery terminals must be protected from short-circuiting and touch
- A battery handle (not included) must be used to lift the battery
- Do not lift or carry the battery while it is in use or operation
- Do not lift the battery by the attached battery cable

5. FEATURES

Item	Description
1	Battery negative (-) dual terminal 5/16" stud, 5/16" insert
2	Battery positive (+) dual terminal 5/16" stud, 5/16" insert
3	Fuse with cover
4	PTFE membrane vent
5	ON/OFF Key and at-a-glance LED
6	LYNK Port
7	Lifting Points

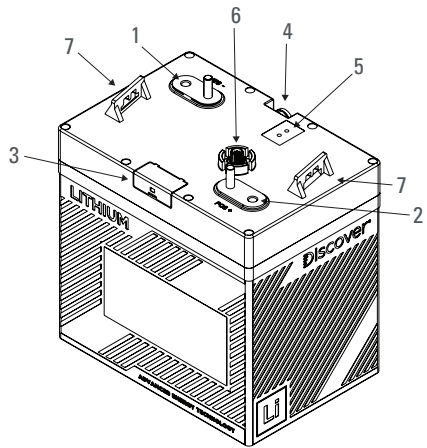

Figure 2. Battery Features

5.1 Battery Fuse

The battery fuse is intended to protect the electronic components of the battery's internal BMS from a high externally generated current. Fuses are relatively inexpensive and easy to replace in the field compared with the BMS, which is a high-cost item and is not serviceable in the field.

NOTE

Additional external DC fusing is required to protect the battery cables from DC overcurrent and to meet installation codes.

5.2 PTFE Membrane Vent

Membrane vents enable the free passage of gases and vapors and equalize the pressure between the internal and ambient conditions. This helps to protect and preserve the internal components of the battery. The PTFE Membrane Vent is a non-resettable type.

5.3 Battery ON/OFF Key

Briefly press the battery's ON/OFF key to switch the battery ON.

Press and hold the ON/OFF key while the battery is ON for longer than 5 seconds, and the key will arm the Remote Power-Off (RPO) Mode. When the battery is in RPO mode, the battery will shut down once the ON/OFF key is released.

5.4 At-a-glance LED

⚠ WARNING

ELECTRIC SHOCK AND FIRE HAZARD

- Always assume the battery main relay is ON (Closed).
- Verify the terminal voltage with a voltmeter before battery handling and installation, even if the At-a-glance LED shows that it may be OFF.

Failure to follow these instructions may result in death or serious injury.

Solid Green LED: The main relay is ON (Closed), the battery is ready for operation.

No LED: The main relay is OFF (Open).

Flashing Orange LED: The main relay is ON (Closed), but one or more of the operating parameters (voltage, current, temperature) has exceeded a fault threshold. Unless the condition is corrected and after a short delay of up to ten seconds, the battery will transition to protection mode, and the main relay will switch to OFF (Open).

Flashing Red LED: The main relay is OFF (Open), the battery is in protection mode, and a fault has occurred.

For a list of faults, refer to **Table 2-4. DLP-GC2 Protections Specifications.**

5.5 LYNK Port

LYNK Port allows multiple batteries in a string to communicate and interact in a closed-loop network and to enable the battery string to be externally monitored. LYNK Port also allows DLP-GC2 batteries to be networked in a closed-loop system with external power conversion devices which can automate the system's configuration and optimize performance. Battery data logs can be downloaded with LYNK Gateway devices and LYNK ACCESS Software.

5.5.1 LYNK Port Pin Assignment

Pin Number	Function
1	ON/OFF Switch
2	LYNK Bus CAN L
3	LYNK Bus CAN H
4	LYNK Bus 12V +
5	LYNK Bus GND

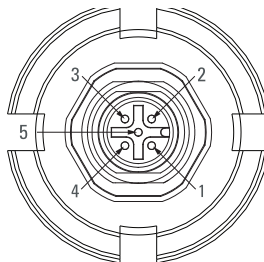

Figure 3. 5-pin M12 A-Code Circular Metric Connector

NOTICE

Crossing pin functions may cause system damage. Do not terminate unused wires to ground, power, or other functions. Isolate unused pins.

5.6 Lifting Points

The battery lifting points are designed to be used with a standard battery lifting strap (not included).



Lifting strap.

6. THEORY OF OPERATION

6.1 Ingress Protection IP67

Ingress protection rates the degree of protection provided by mechanical casings and electrical enclosures against intrusion, dust, accidental contact, and water under specified conditions. The IP67 rating includes testing that indicates no ingress of dust particles and no ingress of a harmful quantity of water when immersed for up to 30 minutes.

IP codes guide suitability for use under different environmental conditions. IP ratings do not indicate fitness for purpose or confer a performance guarantee.

6.2 Internal Heating

The battery is equipped with internal heating. When the battery's internal temperature is below 5°C (41°F) and the battery is either connected to a charging source or SOC is 50% or more, energy is diverted to the internal heating element to avoid the under-temperature fault.

The heating stops when:

1. The battery's internal temperature reaches 8°C (46.4°F).
 - Once the cell temperature reaches this threshold, all the energy is directed to charging the cells.
2. No charge current is detected and SOC is less than 50%.
 - After the heating stops, if the battery's internal temperature drops below 5°C (41°F) and the battery is connected to a charging source, the heater turns ON again.

NOTE

Charging and heating can occur simultaneously. However, the BMS will not allow charging to continue when cell temperature is below 4°C (39.2°F) for 5 seconds.

6.3 Battery Management System

6.3.1 Battery Management System Protections

The Battery Management System's (BMS) primary function is to monitor cell voltage and temperature, and battery current. The BMS uses this information to maintain cell operation within specification. If a parameter falls outside of operating specifications, the BMS will disconnect and protect the battery from:

1. **Overvoltage.** Protection occurs when charge voltages are too high.
2. **Undervoltage.** Protection occurs during discharge when the voltage is discharged too low.
3. **Over-current.** Protection can occur during charge or discharge. This may happen when powering up a load (high inrush current) or from a sustained current above the specified limit.
4. **Over-temperature.** Protection can occur during charge and discharge.
5. **Under-temperature.** Protection can occur during charge and discharge.
6. **Load Qualification.** When the battery is switched on, it will qualify the load attached to the battery to prevent turning on into a reverse polarity, short circuit, mixed voltage system, or large capacitive load.

For trigger and recovery values, refer to **Table 2-4 DLP-GC2 Protection Specifications**.

The BMS will reconnect when recovery thresholds are met. If the BMS disconnects due to low voltage protection, the battery will have to be manually switched ON. If the system has a constant parasitic draw, a physical disconnect switch is recommended to reconnect the battery.

There is a 120-second delay for the battery to be turned back on again after a load qualification fault. This means that if a user attempts to switch the battery OFF after a load qualification fault, the battery cannot be switched back ON again until the 120-second delay is over.

NOTE

- Charge and discharge have different operating temperature limits.
- If the BMS disconnects responding to temperature or current limits, wait for the temperature or current to reach normal operating limits.

6.3.2 Battery Management System Pre-Charge System

The battery is equipped with a Pre-charge System that will energize external capacitive loads before turning on the main relay. The maximum input capacitance for a single battery should not exceed the values published in **Table 2-1. DLP-GC2 Electrical Specifications**.

6.3.3 Battery Management System Load Qualification

When the battery is switched from the OFF state to the ON state, the battery BMS will qualify the external load before turning on the main relay. Load qualification will reject turning on into short circuits, reverse polarity, mixed voltage systems, or capacitive loads that exceed the battery limits.

The battery will attempt Load Qualification up to a maximum of 10 times. After 10 failed attempts at Load Qualification, the battery will switch OFF.

During Load Qualification, or when a load has been disqualified, the at-a-glance LED will flash red.

6.3.4 Battery Management System Cell Balancing

The battery is equipped with cell balancing circuits that compare all cells in a battery and balance the cell voltage at the end of the charge. When the battery is networked with other batteries using the LYNK port, all battery cells are balanced as an entire system and not as an individual battery.

6.3.5 Battery Charge and Discharge Settings

The charge and discharge settings in an Open-loop configuration are set up manually through the controller for the Power Conversion device at the time of installation using the specifications provided in this manual. An Open-loop system using lithium batteries is also known as a drop-in lead-acid replacement system. This compares to a Closed-loop configuration where the BMS controls charge and discharge settings over a connection with the Power Conversion device.

Closed-loop communication with a Power Conversion device requires using a LYNK II Gateway Communication device available from Discover Energy Systems. For details, please refer to the relevant LYNK Gateway Communication User Manual available at www.discoverlithium.com, or contact your Discover Energy Systems provider for assistance.

Refer to the appropriate Application Note available at www.discoverlithium.com for closed-loop parameter setup and integration with specific brands of inverter-chargers and battery chargers.

6.4 LYNK Network Communication

CAN communication is used over the LYNK Network by multiple batteries to coordinate their performance and communicate with accessories such as LYNK Communication Gateways.

NOTICE

The battery has an intelligent CAN termination. Terminating resistors are not required when deploying the battery in a LYNK Network.

6.4.1 LYNK Network Power

The battery provides the LYNK Network with power via the LYNK Port. Discover accessory documentation will specify how many batteries are required to provide sufficient power for the LYNK Network and compatible accessories. Some accessories may require more than one DLP-GC2 battery to provide sufficient power.

NOTICE

Do not use an external power source to power devices over the LYNK Network.

6.4.2 LYNK Network Size

One LYNK Network is limited to 20 DLP-GC2 batteries. The Network is limited to up to 30 devices including batteries, displays, chargers and LYNK Communication Gateway devices.

6.4.3 LYNK Network Cables

IP65 rated LYNK Network cables compatible with the DLP-GC2 battery pin configuration are available from Discover in various lengths.

6.4.4 External ON/OFF Key

Use a momentary button type switch or a latching relay with a key to switch ON/OFF a battery network from a remote location. To toggle the battery network ON/OFF, connect the device to pin 1 of the LYNK Network communication line and the positive terminal of the batteries. Refer to **Figure 4. Remote ON/OFF Operation with Battery Network**.

Momentarily activate the button to switch the battery ON and then momentarily activate the button again to switch the battery OFF.

A latching relay will engage the Remote Power Off (RPO) battery function (refer to Section **5.3 Battery ON/OFF Key**). Setting the key to the ON position for 5 seconds will switch the battery ON engaging RPO Mode. Returning the key to the OFF position will release the battery from RPO Mode and switch the battery OFF.

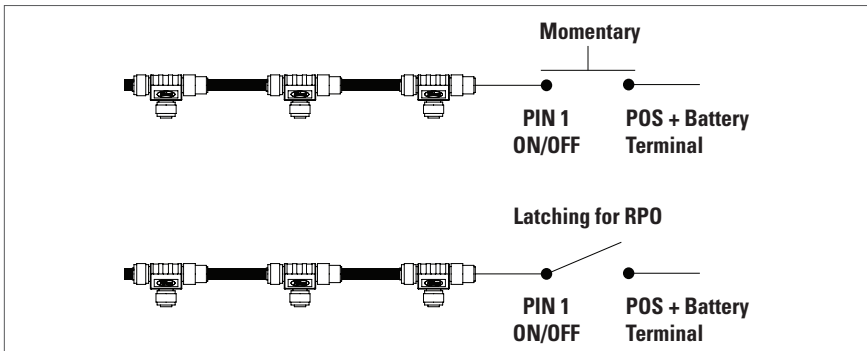

Figure 4. Remote ON/OFF Operation with Battery Network

7. OPTIONAL ACCESSORIES

Optional accessories are available for use with the DLP-GC2 battery:

Accessory	Part Number
DLP B2B-400 (COMM Cable 0.4 meters / 15.75 inches, M-F)	950-0035
DLPTOL-7600 (COMM Cable 7.6 meters / 299.25 inches, M-F)	950-0037
DLPTOL-1800 (COMM Cable 1.8 meter / 70.87 inches, M-F)	950-0036
DLPT Connector (COMMT Connector) with DLP B2B-400 (COMM Cable 0.4 meters / 15.75 inches)	950-0038
DLPT Connector (COMMT Connector, F-F-M)	950-0041
DLP Delta-Q IC Charger Cable (1.8 meters / 70.87 inches, F-Delta-Q)	950-0046
DLP Cable Connector (COMM Connector, M-M)	950-0057
LYNK II Communication Gateway	950-0025
LYNK LITE Communication Gateway	950-0040
SOC GAUGETYPE B CAN Bus Battery Discharge Indicator with 1.8 meters / 70.87 inches cable	950-0039
SOC GAUGETYPE A CAN Bus Battery Discharge Indicator with 1.8 meters / 70.87 inches cable	950-0044

8. INSTALLATION

WARNING

ELECTRIC SHOCK AND FIRE HAZARD

- This equipment must only be installed as specified.
- Do not disassemble or modify the battery.
- If the battery case has been damaged, do not touch exposed contents.
- No user-serviceable parts inside.

Failure to follow these instructions may result in injury.

NOTICE

AES PROFESSIONAL batteries should not be installed in Series.

Failure to follow these instructions will void the warranty.

NOTICE

- For chargers or inverters with temperature compensated charging, disable this feature.
- Do not use or install a battery temperature sensor.
- It is the responsibility of the installer to ensure that all applicable installation requirements and standards are met.

8.1 Tools

- Insulated tools sized to match nuts, bolts, and cables in use
- RMS type Voltmeter
- Post cleaner and wire brush
- Personal protective equipment

8.2 Location

Install the battery in locations that meet the following requirements:

1. **Do not install in direct sunlight.** Avoid installing the battery in an area with high ambient temperature.
2. **Moderate temperatures.** Ambient temperatures should be between 0°C and 40°C (32°F and 104°F). Ambient temperatures of 15°C to 20°C (59°F to 68°F) are ideal for extending LiFePO₄ battery life.
3. **Ventilated.** Do not install in zero-clearance compartments. Maintain at least 50 mm (2 inches) above the top cover for open airflow.
4. **Proper orientation.** Do not install upside down.

Additional requirements for mobile or in-vehicle installations:

1. **Do not install in an engine compartment.** Avoid installing the battery in an area with high ambient temperature.

Secure the battery. Locate the battery in a battery box or battery compartment. Secure the battery or battery box with strapping or a bracket to prevent movement and strain on the battery and cables.

NOTE

The warranty is voided if operated outside of these conditions.

8.3 DC Cables

⚠ CAUTION

FIRE HAZARD

Use cables sized to handle the specified load. Undersized cables can become hot and may potentially catch fire.

Failure to follow these instructions can result in minor to moderate injury.

The DC battery cables must meet the following requirements.

1. **Copper-stranded cable.** DC cables must be stranded, copper, and must be rated 90 °C (194 °C) minimum. The cables must be terminated with lugs that fit the DC terminals.
2. **Minimum cable lengths.** Select a location that minimizes the length of battery cables to reduce voltage drop from impedance leading to reduced performance.
3. **Appropriate cable gauge.** The cables must be capable of carrying the normally expected current, plus a margin of safety.
4. **Proper polarity.** Positive (+) connected to positive (+), and negative (-) connected to (-).

8.4 DC Protection

⚠ CAUTION

FIRE HAZARD

- Use cables sized to handle the specified load. Undersized fuses and disconnects may become overloaded and potentially cause a fire.
- Fuses and disconnects are required to open before the cable reaches its maximum current carrying capability.

Failure to follow these instructions can result in minor to moderate injury.

Additional DC overcurrent protection and a DC disconnect switch are required to protect the system and DC battery cables:

1. **Appropriate size.** Fuses and disconnects must be sized following local codes to protect the wiring in the system and are required to open before the cable reaches its maximum current carrying capability.
2. **Install protection in the positive cable.** The fuse and disconnect should be located as close as possible to the battery and must be installed in the positive cable. Applicable codes may limit how far the protection can be from the battery.

NOTE

- AC circuit breakers and DC circuit breakers are not interchangeable. Check the label on the circuit breaker to ensure it is the correct type and rating. Use only DC circuit breakers.
- The local electrical code in your area may require both positive and negative DC disconnect switches. Always refer to the applicable code and check with the authority having jurisdiction to confirm local requirements.

8.5 Terminal Connections and Hardware

The terminal connections and hardware should meet the following requirements:

1. **Connect to the battery terminal.** All cable lugs must be in direct contact with the battery terminal deck. Do not put washers between the terminal deck and cable lug.
2. **Use the proper torque.** Use a torque wrench to properly adjust terminal hardware torque. Periodically check to ensure torque is correct.

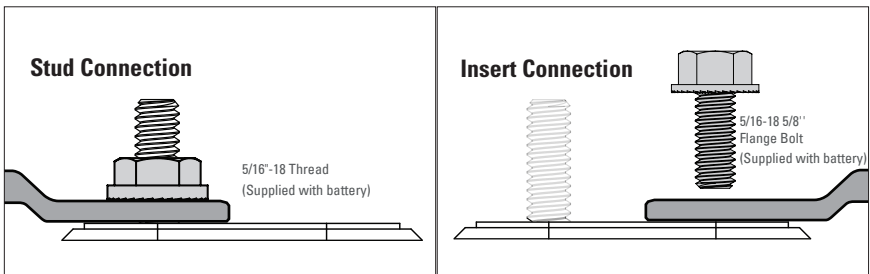

Figure 5. Correct Terminal Installation

NOTICE

- Failure to torque up to specification may increase resistance and lower voltage, leading to burnout of the terminals and voiding the warranty.
- Exceeding 10 Nm (7.4 ft-lb) of torque will damage the terminal or may cause the battery casing to crack, and void the warranty.

NOTE

Without exception, a product experiencing terminal burnout will not be warranted.

8.6 Single Battery Installation Procedure

Equipment must be installed following the standards set by the local authority having jurisdiction.

CAUTION

FIRE HAZARD

Use cables sized to handle the specified load. Undersized cables can become hot and may potentially catch fire.

Failure to follow these instructions can result in minor to moderate injury.

Battery cables (battery to load and battery to charger) must meet the following requirements to optimize performance:

1. **Minimum cable lengths.** Select a location that minimizes the length of battery cables to reduce voltage drop from the impedance.

Equipment must be installed in accordance with the standards set by the local authority having jurisdiction

1. If the circuit of equipment that the battery is installed in has a disconnect, open the disconnect to isolate the battery.
2. Ensure the battery is OFF.
3. Ensure the cable connections are clean and serviceable.
4. Install and secure the battery. Be careful not to make contact between the terminals and any metal mounting, fixture, or body part.
5. Connect battery cables taking care to connect the positive (+) cable to the positive (+) terminal. Connect the negative (-) cable last to avoid sparks. Short circuits may damage the battery, and this will void the warranty.
6. Torque all battery terminals to the recommended terminal torque of 8 to 10 Nm (5.9 to 7.4 ft-lb) to secure cable lugs. **DO NOT EXCEED 10 Nm (7.4 ft-lb).**
7. Install a T connector and attach a Comm cable. Attach the other end of the Comm cable to a LYNK device. Refer to **Section 8.8.2 Network Installation** for complete instructions.
8. Set the battery to ON.
9. Close circuit disconnect (if open).

NOTICE

- Failure to torque up to specification may increase resistance and lower voltage, leading to burnout of the terminals and voiding the warranty.
- Exceeding 10 Nm (7.4 ft-lb) of torque will damage the terminal and may cause the battery case to crack, and void the warranty.

NOTICE

For chargers or inverters with temperature compensated charging, disable this feature. Do not use or install a battery temperature sensor.

8.7 Parallel Battery Installation Procedure

⚠ CAUTION

FIRE HAZARD

Use cables sized to handle the specified load. Undersized cables can become hot and may potentially catch fire.

Failure to follow these instructions can result in minor to moderate injury.

Batteries used in a parallel system must meet the following requirements:

1. **Same model.** Batteries must be the same model.
2. **Equal voltage.** Always ensure that batteries are within 50 mV (0.05 V) of each other, at 95% SOC or higher, before installing them in parallel.

Battery cables (battery to load and battery to charger) must meet the following requirements to optimize performance:

1. **Minimum cable lengths.** Select a location that minimizes the length of battery cables to reduce voltage drop from the impedance.

Interconnection cables (battery to battery) must meet the following requirements to optimize performance:

1. **Equal cable gauge.** The interconnection cables should be the same gauge.
2. **Equal cable length.** The interconnection cables should be of equal length.

Equipment must be installed in accordance with the standards set by the local authority having jurisdiction.

1. If the circuit of equipment that the batteries are installed in has a disconnect, open the disconnect to isolate the batteries.
2. Ensure that all batteries are set to OFF.
3. Ensure the cable connections are clean and serviceable.
4. Install and secure new batteries. Be careful not to make contact between the terminals and any metal mounting, fixture, or body part.
5. Connect battery positive (+) cables between the battery positive (+) terminals with firmly tightened terminal hardware.

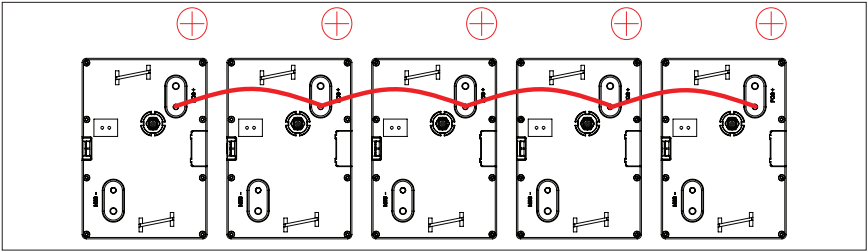

Figure 6. Positive Parallel Connections.

6. Connect battery negative (-) cables between the battery negative (-) terminals with firmly tightened terminal hardware.

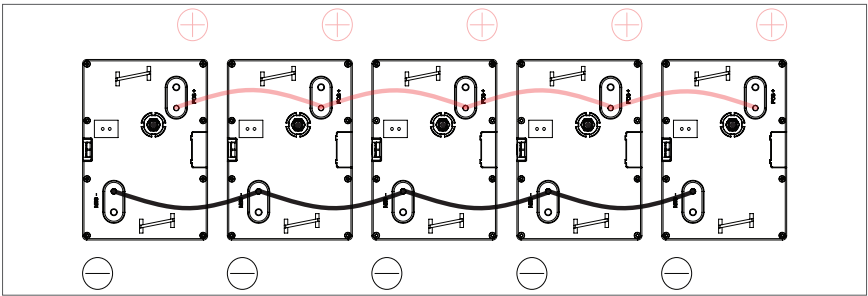

Figure 7. Negative Parallel Connections.

7. Connect the load positive (+) cable and load negative (-) cable to the opposing ends of the parallel batteries.

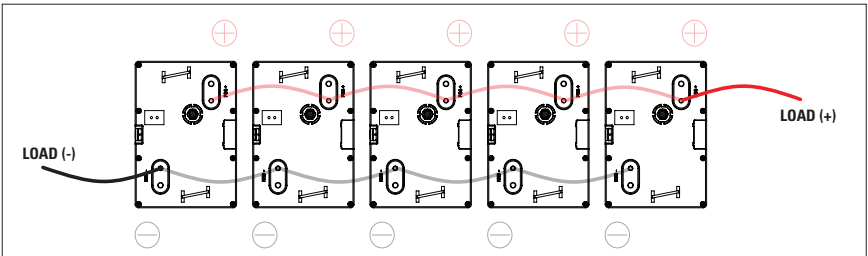

Figure 8. Load Connections.

8. Connect the charger positive (+) cable and charger negative (-) cable to the opposing ends of the parallel batteries.

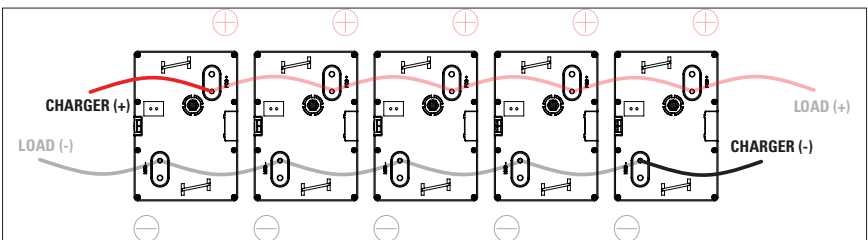

Figure 9. Charger Connections.

9. Torque all battery terminals to the recommended terminal torque of 8 to 10 Nm (5.9 to 7.4 ft-lb) to secure cable lugs. **DO NOT EXCEED 10 Nm (7.4 ft-lb).**
10. Install a T connector on each battery and interconnect each battery in a daisy chain with a Comm cable. If an LYNK device is being used, attach a Comm cable from the T Connector of the last battery in the string to the LYNK device. Refer to Section **8.8.2 Network Installation** for complete instructions.
11. Energize the system by setting all the batteries to ON.
12. Close the circuit disconnect (if open).

NOTICE

- Failure to torque up to specification may increase resistance and lower voltage, leading to burnout of the terminals and voiding the warranty.
- Exceeding 10 Nm (7.4 ft-lb) of torque will damage the terminal and may cause the battery case to crack, and void the warranty.

NOTE

Whenever replacing an old battery in a string, use a battery of the same age, model, capacity, and voltage.

NOTE

Before installing a battery in parallel, ensure that all the batteries are charged to 100% SOC.

8.8 LYNK Network

8.8.1 Network Layout

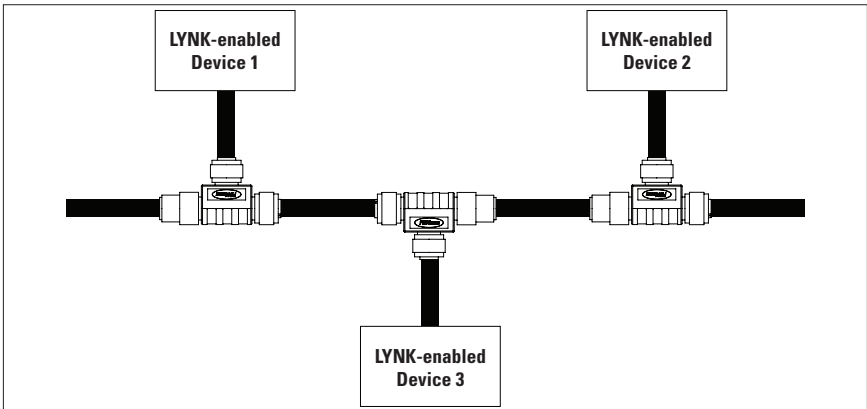

Figure 10. Network Layout.

8.8.2 Network Installation

Networking Guidelines:

- **Separate data and power cables.** Allow for separation between data and power cables. Avoid data interference caused by running network cables bundled with power cables.
- **Allow for LYNK Network cable slack.** Ensure that LYNK Network cables are slack and not in tension.
- **Isolate the LYNK Network.** Do not mix other networks with the LYNK Network.

NOTICE

Mixing the LYNK Network with other networks may result in equipment malfunction and damage.

NOTE

Termination resistors are not required when networking with the LYNK Network.

1. Mount the devices according to their installation instructions before beginning network installations.
2. Attach the **950-0038 DLPT Connector** to each battery. Ensure that the mating connectors are securely fastened.
3. Insert the male end of the cable into the female end of the **950-0038 DLPT Connector** and vice versa.
4. Repeat until all nodes have been attached.
5. Network with other devices and accessories as needed.

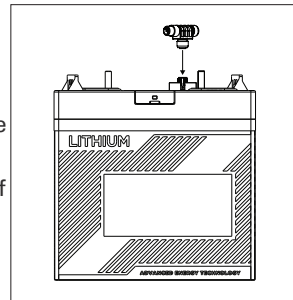

Figure 11. 950-0038 DLPT Connector

Figure 12. Network Installation

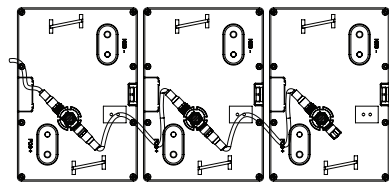
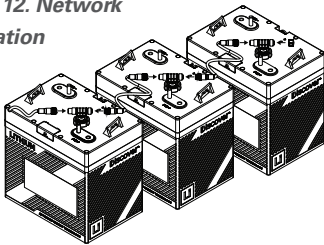

Figure 13. Complete Network Installation

8.8.3 Testing and Verification of the LYNK Network

Network verification must be completed with one of **950-0044 SOC GAUGE TYPE A**, **950-0039 SOC GAUGE TYPE B**, **950-0025 LYNK II**, or **950-0040 LYNK LITE Communication Gateway**.

If a **SOC GAUGE TYPE A** or **B** is networked:

- If the display illuminates, power can be confirmed as ON for the LYNK Network.
- If the display is showing SOC, communications are confirmed as active for the LYNK Network.

If an **LYNK II** or **LYNK LITE Communication Gateway** is networked:

- If the LYNK Network Bus indication LED is illuminated, power and communications are confirmed as active for the LYNK Network.
- LYNK ACCESS Software can be used via a computer to confirm the number of batteries in the LYNK Network.

9. OPERATION

The BMS prevents battery operation outside of specified operating conditions. Make sure to understand each of these protections and how to set up the system accordingly. Refer to **Table 2-4 DLP-GC2 Protection Specifications**.

NOTICE

Intentional bypassing of the BMS to operate the battery outside maximum and minimum limits will void the warranty.

9.1 Low Voltage Cut-Off

As controlled by the application, the low voltage cut-off should be programmed at or above the Low Voltage Disconnect in **Table 2-1 DLP-GC2 Electrical Specifications**. This ensures the load will disconnect before the BMS is forced to enter low voltage protection.

NOTICE

Storing or leaving the battery at 0% SOC will lead to irreversible damage and void the warranty.

9.2 State of Charge

A voltage-based battery meter designed for lead-acid batteries will not provide an accurate state-of-charge (SOC) for lithium batteries. The following devices are available from Discover and will provide an accurate state of charge:

- **SOC GAUGETYPE A**
- **SOC GAUGETYPE B**

The following devices are available from Discover and will communicate an accurate state of charge to other devices:

- **LYNK II Communication Gateway**
- **LYNK LITE Communication Gateway**

9.3 Charging

Each electrical system will have different characteristics and balance-of-system components. To optimize system performance, modifications to the charger's settings may be required.

NOTICE

- Always confirm that the charging device is incapable of producing transient spikes that exceed the published terminal voltage limits for the battery.
- Never charge a visibly damaged or frozen battery.
- Always confirm the charging curve meets the battery's charging requirement.

9.3.1 Closed-Loop Charging

Closed-loop charging is a charging method whereby the battery communicates with a charger and controls the charge voltage and current. Closed-loop charging is available with compatible chargers directly connected to the LYNK port or with compatible chargers through the **LYNK II** or **LYNK LITE Communication Gateway**. Closed-loop charging reduces charge time and increases balancing efficiency when compared to open-loop Charging.

Refer to the appropriate Application Note available from discoverlithium.com for closed-loop parameter setup and integration with specific brands of inverter-chargers and battery chargers.

9.3.2 Open-Loop Charging

Open-loop charging is a method of charging where the battery and charger do not have communication. In this method, the charger must be configured manually with the appropriate charge algorithm settings.

For charging parameters, refer to **Table 2-1 DLP-GC2 Electrical Specifications**.

9.3.3 When to Charge the Battery

- **Opportunity charging is OK:** Charging the battery after every use will not reduce its cycle life.
- **Partial state-of-charge is OK:** If the battery SOC is greater than 10% at the end of discharge, it does not require an immediate charge.
- **Charge if below 10% SOC:** If the battery has been discharged below 10% SOC, it must be charged within 24 hours to avoid permanent damage to the battery. Otherwise, irreversible damage to the battery cells will occur in a very short period of time.
- **Low charge current extends life.** Charging at 50% of nominal current or lower helps extend battery cycle life.
- **Proper temperature.** Ensure charging is within the charge temperatures specified in **Table 2-3 DLP Environmental Specifications**.

NOTICE

The battery must be charged within 24 hours if it has been discharged below 10% SOC. Otherwise, irreversible damage to the battery cells will occur in a very short time and void the warranty.

NOTICE

- When battery cells are between -17°C (-4°F) and 5°C (41°F) and either connected to a charging source or SOC is 50% or more, energy is diverted to the internal heater until the battery cells reach 8°C (46.4°F).
- If the BMS triggered the Under-temperature in Charge protection, the battery will not allow charging until the cell temperature is 4°C (39.2°F).

9.3.4 Charging with a Lead-Acid Charger

⚠ CAUTION

FIRE AND BURN HAZARD

Do not perform an equalization charge on lithium batteries.

Failure to follow these instructions can result in minor to moderate injury.

- **Not recommended.** It is not recommended to use a lead-acid charger for the reasons stated below.
- **It is possible.** Short-term charging with a lead-acid charger is possible only if the bulk and absorption voltages are equal to or below the bulk voltage. Refer to **Table 2-1 DLP Electrical Specification** for charging parameters and **Figure 14 Charge Graph**.
- **GEL profiles.** GEL profiles are typically the lead-acid settings closest to the recommended Lithium settings.
- **No equalization.** Do not perform an equalization charge on lithium batteries.
- **No temperature compensation.** Temperature compensation must be disabled.

NOTICE

Some lead-acid charge profiles are within the LiFePO₄ charging voltages. However, many will exceed the BMS high voltage protection limits. This will result in the BMS disconnecting at the end of the charge cycle and likely causing the charger status indicator to display an error.

NOTICE

Temperature compensation must be disabled.

9.3.5 Charging with Alternators

- **Not recommended.** Due to the risk of overheating the alternator and BMS protection disconnecting the battery from the electrical system, using an alternator as a charge source without a DC-DC converter is not recommended.
- **It is possible.** Charging is possible with a DC-DC converter using a lithium charge profile that matches DLP charge specifications attached to the alternator.

NOTICE

If the alternator charge voltage or current is too high, the BMS will protect the battery by disconnecting the battery from the system. A large voltage spike may also be created in a one-battery system, potentially damaging both the alternator and BMS.

NOTICE

LiFePO₄ batteries are so efficient the alternator may burn itself out over extended periods of output at or close to peak current.

9.4 Charging Profile

Standard open-loop charging for the battery should include both Bulk and Absorption phases. Refer to **Table 2-1 DLP-GC2 Electrical Specifications** for open-loop charging parameters.

Refer to the appropriate Application Note available from www.discoverlithium.com for closed-loop parameter setup and integration with specific brands of inverter-chargers and battery chargers.

NOTE

Charging at 50% of nominal current or lower will extend battery cycle life.

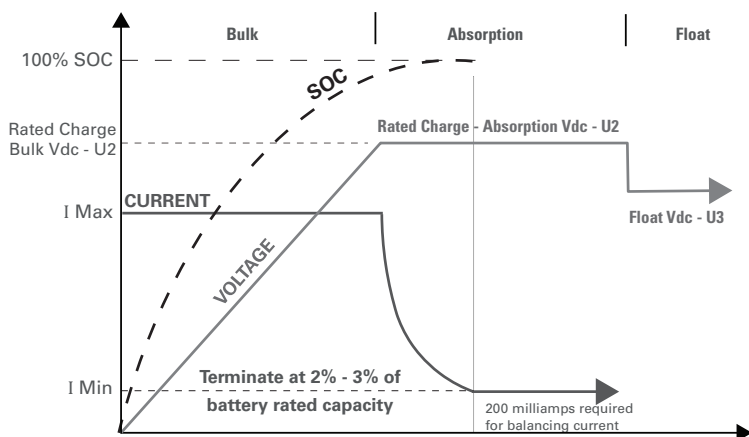

Figure 14. Charge Graph

9.4.1 Bulk Charge

Bulk phase. The first phase of the charging process is the Bulk Charge, also referred to as the constant current phase. This is when the charger's maximum current is directed to the battery until the desired voltage is reached. The Bulk phase will recharge the battery to approximately 90-95% SOC.

If the charging source is a generator or other charge source that is not efficient at low output current, a single-stage charge may be appropriate. A single-stage charge will only complete the Bulk phase portion of the charge curve. This method should return the battery to between 90-95% SOC.

Refer to **Table 2-1 DLP-GC2 Electrical Specifications** for charging parameters.

Fast Charge. An alternative to conventional charging using a higher voltage to increase the charging current to charge the battery quicker without damaging it. Fast charging increases the battery temperature to operate closer to its operating limit.

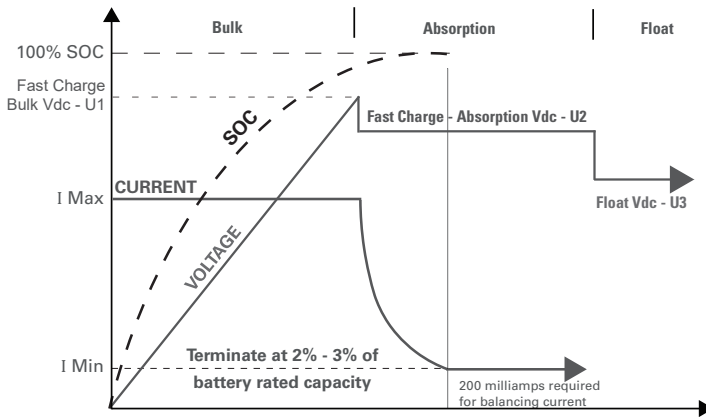

Figure 15. Fast Charge Graph

9.4.2 Absorption Charge

Absorption phase. The second phase of the charging process is Absorption Charge, also referred to as the constant voltage phase. This is when the charger reduces current accordingly to maintain the desired voltage.

Refer to **Table 2-1 DLP-GC2 Electrical Specifications** for charging parameters.

9.4.3 Equalization Charge

⚠ CAUTION

FIRE AND BURN HAZARD

Do not perform an equalization charge on lithium batteries.

Failure to follow these instructions can result in minor to moderate injury.

Do not equalize charge. Do not equalize charge Lithium batteries. Equalization charging is intended only for lead-acid batteries. Equalization charge is a purposeful overcharge that targets a voltage above standard charge voltage to remove sulphate crystals that form on lead-acid plates over time.

9.4.4 Float Charge

Float phase. Float charge, the third phase of charging, is optional. During this stage, the battery is maintained at 100% SOC for extended periods of time, counteracting any self-discharge or parasitic loads.

- **Not necessary.** Float charging is not necessary.

If needed refer to **Table 2-1 DLP-GC2 Electrical Specifications** for float parameters.

10. ROUTINE INSPECTION

Periodically inspect the battery system:

1. Ensure that all DC cables are secure and fasteners are tight
2. Ensure all Networking cables and connectors are secure and tight.
3. Ensure that the installation location is clean and free from debris.
4. Inspect for cracks in the battery case.
5. Replace any damaged batteries.
6. Replace any damaged cables.

11. REPLACING THE FUSE

CAUTION

ELECTRIC SHOCK

- Do not touch the energized surfaces of any electrical component in the battery system.
- Before servicing the battery, follow all procedures to fully de-energize the battery system.
- Follow 1.4 **Safe Handling Procedures** when handling the battery.

Failure to follow these instructions may result in injury.

Table 11-1. DLP-GC2 Fuse Specifications

Discover Service Part Number	960-0018	960-0019	960-0020
Fuse Rating	58V 200A	58V 125A	58V 60A
Applicable	DLP-GC2-12V 900-0051	DLP-GC2-24V 900-0052	DLP-GC2-36V 900-0053 DLP-GC2-48V 900-0054
Fuse Terminal Torque	8 to 10 Nm (5.9 to 7.4 ft-lb). DO NOT EXCEED 10 Nm (7.4 ft-lb).		

This task should be performed by qualified personnel:

- Use only insulated tools
- Wear personal protective equipment
- The battery system must be de-energized
- Battery cables must be disconnected
- Battery terminals must be protected from short-circuiting and touch

Refer to Sections **8.5 Terminal Connections and Hardware**, **8.6 Single Battery Installation Procedure**, and **8.7 Parallel Battery Installation Procedure**.

1. Ensure that the DC system is de-energized, and the battery charger and all loads are disconnected. If the circuit of equipment that the battery is installed in has a disconnect, open the disconnect to isolate the batteries.
2. If connected to others, remove the battery and isolate it.
3. Protect the battery terminals from short-circuiting and touch by covering them with terminal covers or electrically rated tape.

4. Open the fuse cover and remove the nuts holding the fuse and replace it with a new fuse paying strict attention to orientation and the fuse ratings in **Table 11-1 DLP-GC2 Fuse Specifications**.
5. Torque the nut holding the new fuse to 8 to 10 Nm (5.9 to 7.4 ft-lb). **DO NOT EXCEED 10 Nm (7.4 ft-lb)**.
6. After removing the terminal protection, reinstall the battery into the system and replace the fuse cover.
7. If installed, close the disconnect to complete the circuit of equipment and energize the battery system.

NOTICE

- Failure to torque up to specification may increase resistance and lower voltage, leading to burnout of the terminals and voiding the warranty.
- Exceeding 10 Nm (7.4 ft-lb) of torque will damage the terminal and cause the battery case to crack, and void the warranty.

12. STORAGE

Leaving the battery connected to a trickle load or power electronics will cause the battery to be discharged during storage. Without any load, the battery will self-discharge by approximately 3% per month while in storage. After storage, charge the battery to 100% SOC and perform at least one full discharge and charge cycle before returning the battery to service.

1. **Store at 95% SOC or greater.** To store the battery for a period of up to 6 months, the battery must be initially put into storage at 95% SOC or greater. It must remain disconnected from all loads and power electronics during the storage period.
2. **Switch OFF the battery.** Set the battery to OFF.
3. **Check SOC every 6 months.** Recharge the battery to above 95% SOC at least every 6 months.
4. **Proper storage temperature.** Ensure storage is within the temperatures specified below.
 - 1 Month storage temperature -20°C to 45°C (-4°F to 113°F)
 - 6 Month storage temperature -10°C to 30°C (14°F to 86°F)

NOTICE

- Leaving the battery connected to a load or power electronics during storage may subject the battery to a trickle drain, resulting in irreversible damage and void the warranty.
- Storage outside of specified temperatures will result in irreversible damage and void the warranty.
- Storing or leaving the battery at 0% SOC will cause irreversible damage and void the warranty.
- Allowing the battery to self-discharge below an open-circuit voltage of 3.0VPC will cause irreversible damage and void the warranty.

13. BATTERY FIRMWARE AND DATA LOGS

Always ensure the battery is operated using the latest firmware. A **LYNK Communication Gateway** device and **LYNK ACCESS** Software for 64-bit Windows 10 are required to update the battery firmware and to download data logs from the battery. **LYNK Communication Gateway** devices are available from Discover Energy Systems dealers and distributors. **LYNK ACCESS** Software and the latest battery operating firmware can be obtained from the Discover Energy Systems website at discoverlithium.com.

14. TROUBLESHOOTING

Data logs from each battery are required for accurate troubleshooting and any warranty claim. **LYNK ACCESS** Software for 64-bit Windows 10 will be required to download the data logs from each battery in the system via a USB connection to a **LYNK Communication Gateway** device networked to all batteries in the system. System owners are encouraged to install a **LYNK Communication Gateway** in their system and install **LYNK ACCESS** software on a laptop to monitor and troubleshoot their system.

15. RELATED INFORMATION

Find information about Discover Energy Systems at www.discoverlithium.com.

For warranty information, see 885-0031 Discover AES PROFESSIONAL Warranty Policy.

16. GLOSSARY OF TERMS, ABBREVIATIONS, AND ACRONYMS

DLP - AES PROFESSIONAL Battery	LFP - LiFePO ₄ Lithium Iron Phosphate
BMS - Battery Management System	SOC - State of Charge
DOD - Depth of Discharge	VPC - Volts Per Cell